

Shaft Couplings

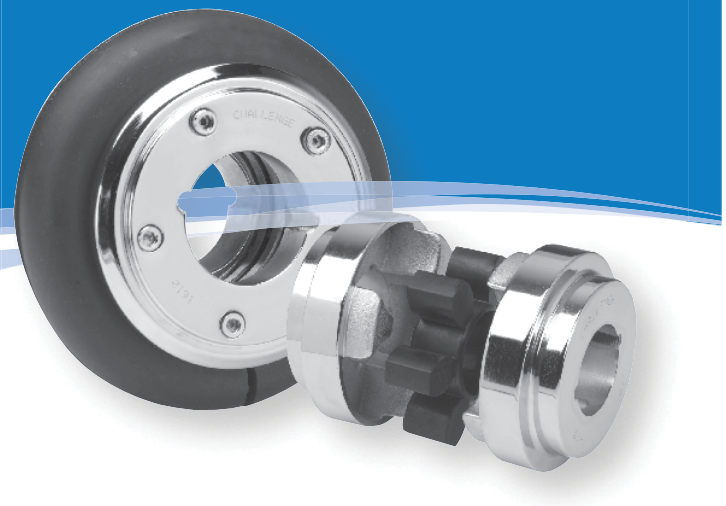

Features

FFX

- Up to 14675 Nm torque on 6 pole motors
- Up to 4° angular misalignment
- Up to 12° 'wind up' shock absorption
- Can accommodate simultaneous maximum misalignment in all planes
- Tyre can be changed without moving prime mover or driven machine
- Visual inspection of tyre to detect wear
- Zero backlash makes the FFX ideal for reversing duties as the load carrying cords are wound in both directions. Reversing drives are not a problem
- Steel clamping rings used throughout the range for superior tyre/clamping ring grip
- Fire resistant and anti static (FRAS) tyres available
- No lubrication required
- Taper bush and pilot bore flanges available

HRC

- Designed specifically for use with IEC motors
- Torques up to 3150 Nm
- Up to 1° angular misalignment
- Good shock absorption properties
- Quick and easy assembly
- Taper bush and Pilot bore flanges available
- High grade cast iron hubs
- Fail safe operation

NPX

- Designed to industry standard
- Available with three part flanges, thus allowing the segments to be changed without disturbing either the driving or driven shaft
- High levels of torsional flexibility
- High speed capability
- Suit IEC electric motor applications
- Taper bore and pilot bore flanges

RPX

- Fully machined with curved jaw design. This reduces vibration and allows for increased shock loading
- Designed to industry standard
- High torque for size
- Taper bore and pilot bore flanges
- 92 shore (yellow) and 98 shore (red) elements available

JAW

- International design
- Low cost wide range of sizes from 16 mm to 127 mm diameter

CHAIN

- High torque capacity
- Bores from 12 mm to 150 mm diameter
- Fully sealed casing with 'O' rings

FFX Tyre Coupling Selection

Tyre Coupling selection procedure

- 1] **Service Factor.**
From Table 1 on page 247, select the service factor that is appropriate for the application
- 2] **Design Power.**
Multiply the absorbed power of the driven machine, in kW, by the service factor, from step 1) to obtain the design power. If the absorbed power is not known, use the prime mover power.
- 3] **Tyre coupling size selection.**
Refer to Table 2 on page 247.
Read down the left hand vertical column to the required speed
Read horizontally across on the speed line until a power equal to or in excess of the design power, from step 2), is reached.
Read vertically to the top of the column to obtain the correct size of tyre coupling.
- 4] **Bore dimensions.**
From the dimensions Table on page 248, check that the selected coupling will fit the shafts.



Tyre Coupling selection example

Select a Challenge tyre coupling to drive a reciprocating pump from a 980 rev/min, 30 kW electric motor. The pump absorbs 24 kW and runs for 16 hours/day. The motor shaft is 60 mm diameter and the pump shaft 55 mm diameter. Taper bush flanges are required for both shafts.

- 1] **Service factor.**
From Table 2 on page 247, the service factor for this application is 1.9
- 2] **Design power.**
Using the absorbed power of the pump, the design power is $24 \times 1.9 = 45.6$ kW
- 3] **Tyre coupling size selection.**
Refer to Table 2 on page 247
By reading down and interpolating for the required speed of 980 rev/min, it is seen that an FFX 090 will transmit 50.45 kW which is in excess of the 45.6 kW required from step 2)
- 4] **Bore dimensions.**
From the dimensions Table on page 248, it is seen that both 'F' and 'H' flanges on an FFX 090 take a 2517 taper bush which are available with bores to suit the shaft requirements of the application.

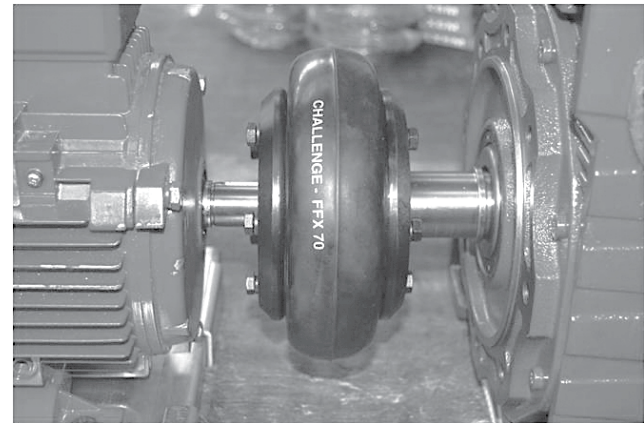

FFX Tyre Coupling Selection

Table 1, Service Factors

Special cases For applications where shock, vibration and torque fluctuations occur – consult Challenge	Type of prime mover					
	'Soft' Starts			'Heavy' Starts		
	Electric motors and other smooth running prime movers			Internal Combustion Engines		
	Number of hours per day running					
Type of driven machine	10 and under	over 10 - 16 incl	over 16	10 and under	over 10 - 16 incl	over 16
Uniform load Light duty agitators, belt conveyors for sand etc., fans upto 7.5 kW, centrifugal compressors and pumps,	0.8	0.9	1.0	1.3	1.4	1.5
Moderate load Variable density agitators, belt conveyors (non-uniform loads), fans over 7.5 kW, other rotary compressors and pumps, generators, machine tools, printing machinery, laundry machinery, rotary screens, rotary woodworking machinery	1.3	1.4	1.5	1.8	1.9	2.0
Heavy load Reciprocating compressors and pumps, positive displacement blowers, heavy duty conveyors such as screw, bucket etc., hammer mills, pulverisers, presses, shears, punches, rubber machinery	1.8	1.9	2.0	2.3	2.4	2.5
Severe load Crushers – gyratory, jaw, roll etc., rolling mills, calenders, quarry machinery, vibrating screens	2.3	2.4	2.5	2.8	2.9	3.0

Table 2, Power Ratings (kW)

Rotational speed in rev/min	FFX 40	FFX 50	FFX 60	FFX 70	FFX 80	FFX 90	FFX 100	FFX 110	FFX 120	FFX 140	FFX 160	FFX 180	FFX 200	FFX 220	FFX 250
100	0.28	0.87	1.58	2.59	4.06	5.16	6.83	9.09	14.2	26.7	41.8	65.4	96.8	120	154
500	1.41	4.36	7.88	12.9	20.2	25.7	34.1	45.4	71.4	134	209	327	484	601	767
700	1.97	6.10	11.0	18.1	28.4	36.0	47.7	63.6	99.8	187	292	458	678	842	1074
720	2.02	6.26	11.3	18.6	29.2	37.1	49.1	65.4	103	192	301	471	697	866	1104
800	2.25	6.97	12.5	20.7	32.4	41.2	54.5	72.3	114	214	334	523	775	962	1227
900	2.53	7.84	14.1	23.3	36.5	46.3	61.4	81.8	128	241	376	589	872	1082	1380
960	2.69	8.36	15.1	24.8	38.9	49.4	65.5	87.3	137	257	401	628	929	1154	1472
1000	2.81	8.71	15.7	25.9	40.6	51.5	68.2	90.9	143	267	419	655	968	1203	1534
1200	3.37	10.4	18.9	31.0	48.6	61.8	81.8	109	171	321	502	785	1162	-	-
1400	3.93	12.2	22.0	36.2	56.8	72.1	95.5	127	200	375	585	916	-	-	-
1440	4.04	12.5	22.6	37.2	58.4	74.2	98.3	131	206	385	602	942	-	-	-
1500	4.21	13.0	23.6	38.8	60.9	77.3	102	136	214	401	627	982	-	-	-
1800	5.05	15.6	28.3	46.5	73.0	92.7	123	164	257	481	-	-	-	-	-
2000	5.62	17.4	31.5	51.8	81.1	103	136	182	286	-	-	-	-	-	-
2500	7.02	21.7	39.3	64.7	102	129	145	-	-	-	-	-	-	-	-
2880	8.08	25.0	45.3	74.5	117	149	-	-	-	-	-	-	-	-	-
3000	8.42	26.1	47.2	77.6	122	155	-	-	-	-	-	-	-	-	-
3500	9.82	30.4	55.1	90.6	-	-	-	-	-	-	-	-	-	-	-
4000	11.2	34.8	63.0	-	-	-	-	-	-	-	-	-	-	-	-
4500	12.6	39.1	-	-	-	-	-	-	-	-	-	-	-	-	-

All power ratings are constant torque
Interpolate for speeds not listed

Every effort has been taken to ensure that the data listed in this catalogue is correct. Challenge accepts no liability for any inaccuracies or damage caused.

FFX Tyre Couplings

FFX Tyre Coupling Data

Coupling Size	Bush Size	Max Bore		Pilot Bore	Types F & H				Type B		Weight# kg		
		Metric	Inch		A	B	C	M *	F	D		F	D
040B	-	32	-	12	104	-	82	11.0	-	-	33	22	0.84
040F	1008	25	1"	-	104	-	82	11.0	33.0	22	-	-	0.84
040H	1008	25	1"	-	104	-	82	11.0	33.0	22	-	-	0.84
050B	-	38	-	15	133	79	100	12.5	-	-	45	32.5	1.26
050F	1210	32	1.1/4"	-	133	79	100	12.5	37.5	25	-	-	1.26
050H	1210	32	1.1/4"	-	133	79	100	12.5	37.5	25	-	-	1.26
060B	-	45	-	18	165	103	124.5	16.5	-	-	55	38.5	2.10
060F	1610	42	1.5/8"	-	165	103	124.5	16.5	41.5	25	-	-	2.10
060H	1610	42	1.5/8"	-	165	103	124.5	16.5	41.5	25	-	-	2.10
070B	-	50	-	22	187	80	142	11.5	-	-	46.5	35	3.26
070F	2012	50	2"	-	187	80	142	11.5	44.5	33	-	-	3.26
070H	1610	42	1.5/8"	-	187	80	142	11.5	42.5	31	-	-	3.15
080B	-	60	-	25	211	98	165	12.5	-	-	55	42.5	5.15
080F	2517	65	2.1/2"	-	211	98	165	12.5	58.5	46	-	-	5.15
080H	2012	50	2"	-	211	98	165	12.5	45.5	33	-	-	4.83
090B	-	70	-	28	235	108	187	13.5	-	-	63.5	50	7.46
090F	2517	65	2.1/2"	-	235	108	187	13.5	59.5	46	-	-	7.35
090H	2517	65	2.1/2"	-	235	108	187	13.5	59.5	46	-	-	7.35
100B	-	80	-	32	254	120	214	13.5	-	-	70.5	57	10.4
100F	3020	75	3"	-	254	120	214	13.5	65.5	52	-	-	10.4
100H	2517	65	2.1/2"	-	254	120	214	13.5	59.5	46	-	-	9.87
110B	-	90	-	30	279	134	232	12.5	-	-	70.5	58	13.1
110F	3020	75	3"	-	279	134	232	12.5	64.5	52	-	-	12.3
110H	3020	75	3"	-	279	134	232	12.5	64.5	52	-	-	12.3
120B	-	100	-	38	314	143	262	14.5	-	-	84.5	70	17.7
120F	3525	100	4"	-	314	140	262	14.5	80.5	66	-	-	17.3
120H	3020	75	3"	-	314	140	262	14.5	66.5	52	-	-	16.7
140B	-	130	-	75	359	178	313	16.0	-	-	110	94	23.3
140F	3525	100	4"	-	359	178	313	16.0	82.0	66	-	-	23.4
140H	3525	100	4"	-	359	178	313	16.0	82.0	66	-	-	23.4
160B	-	140	-	75	402	197	347	15.0	-	-	117	102	37.6
160F	4030	115	4.1/2"	-	402	197	347	15.0	92.4	77.4	-	-	34.1
160H	4030	115	4.1/2"	-	402	197	347	15.0	92.4	77.4	-	-	34.1
180B	-	150	-	75	470	205	396	23.0	-	-	137	114	51.6
180F	4535	125	5"	-	470	205	396	23.0	112.0	89	-	-	44.3
180H	4535	125	5"	-	470	205	396	23.0	112.0	89	-	-	44.3
200B	-	150	-	85	508	206	433	24.0	-	-	138	114	61.1
200F	4535	125	5"	-	508	206	433	24.0	113.0	89	-	-	56.3
200H	4535	125	5"	-	508	206	433	24.0	113.0	89	-	-	56.3
220B	-	160	-	85	562	224	472	27.5	-	-	154.5	127	83.6
220F	5040	125	5"	-	562	224	472	27.5	129.5	102	-	-	75.6
220H	5040	125	5"	-	562	224	472	27.5	129.5	102	-	-	75.6
250B	-	190	-	88	628	254	532	28.5	-	-	160.5	132	109.0
250F	5040	125	5"	-	628	254	532	28.5	155.5	127	-	-	106.0
250H	5040	125	5"	-	628	254	532	28.5	155.5	127	-	-	106.0

Notes

= Is the weight for a half coupling.

* = M is half the distance between flange faces

NB. All flexible tyres have an angular misalignment capacity up to 4°

Fire resistant and anti static (FRAS) tyres are available

Challenge standard tyres are manufactured from natural rubber with an operating temperature span between -50°C and +50°C.

Challenge FRAS tyres are manufactured from chloroprene rubber and have an operating temperature span between -15°C and +70°C

All Challenge FFX Flanges up to size 180 are produced from forged C45 steel. From size 200 upwards are produced from GGG.

FFX Tyre Couplings

FFX Tyre Coupling Data

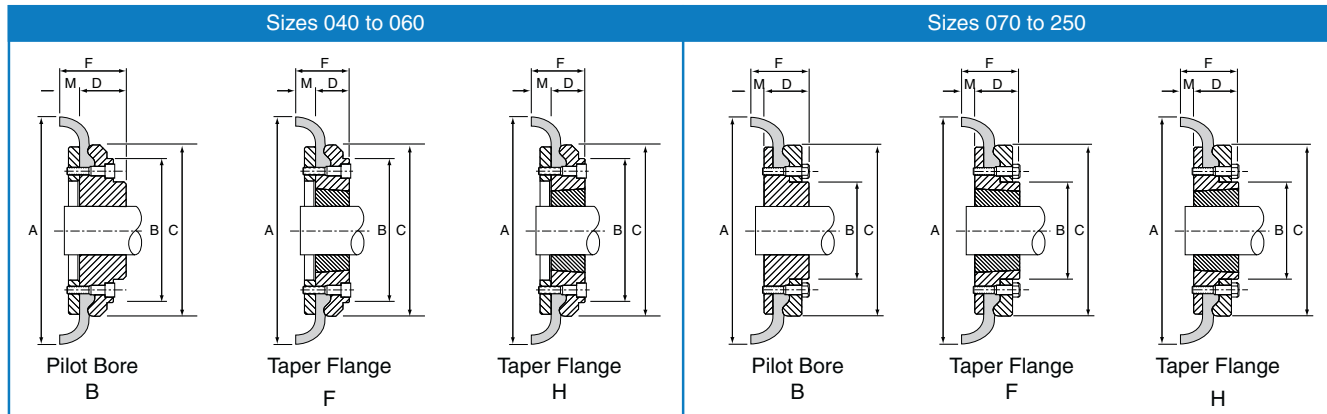

FFX Coupling Installation and Operational Data

Coupling Size	Flange Face Spacing mm	Gap Between Tyre Ends mm	Nominal Torque Nm	Max Speed rev/min	Max Parallel Misalignment mm	Max End Float* mm	Clamping Screw Size	Torque Nm
40	22	2	24	4500	1.1	1.3	M6	15
50	25	2	66	4500	1.3	1.7	M6	15
60	33	2	127	4000	1.6	2.0	M6	15
70	23	3	250	3600	1.9	2.3	M8	24
80	25	3	375	3100	2.1	2.6	M8	24
90	27	3	500	3000	2.4	3.0	M10	40
100	27	3	675	2600	2.6	3.3	M10	40
110	25	3	875	2300	2.9	3.7	M10	40
120	29	3	1330	2050	3.2	4.0	M12	50
140	32	5	2325	1800	3.7	4.6	M12	55
160	30	5	3770	1600	4.2	5.3	M16	80
180	46	6	6270	1500	4.8	6.0	M16	105
200	48	6	9325	1300	5.3	6.6	M16	120
220	55	6	11600	1100	5.8	7.3	M20	165
250	59	6	14675	1000	6.6	8.2	M20	165

* End Float, alternatively called axial misalignment

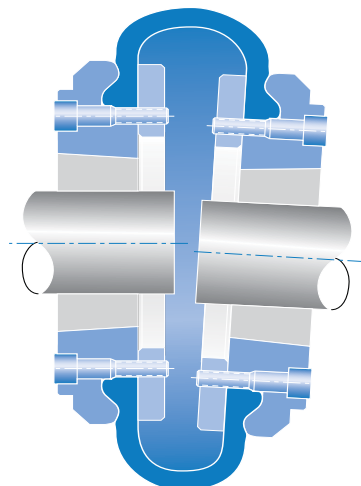

Accommodate simultaneous maximum misalignment in all planes.

FFX Tyre Coupling Installation

Installation Instructions

- 1] Clean all parts
- 2] Assemble the flanges onto the shafts after connecting the clamping rings loosely to them
- 3] Move the flanges along the shafts until dimension '2M' is obtained (see Table 3). Ensure there is sufficient gap between the shaft ends to allow for any axial movement
- 4] Check the alignment in both parallel and angular planes to ensure the shafts are aligned as accurately as possible – the more accurate the alignment, the less the tyre wear. See Table 3 for misalignment values
- 5] Fit the tyre into the gap between the flange and clamping ring, ensuring the tyre bead is correctly located. When correctly seated, the tyre gap should match the value in Table 4
- 6] Tighten the clamping ring screws alternately, and gradually, until the correct torque is achieved (see Table 3)

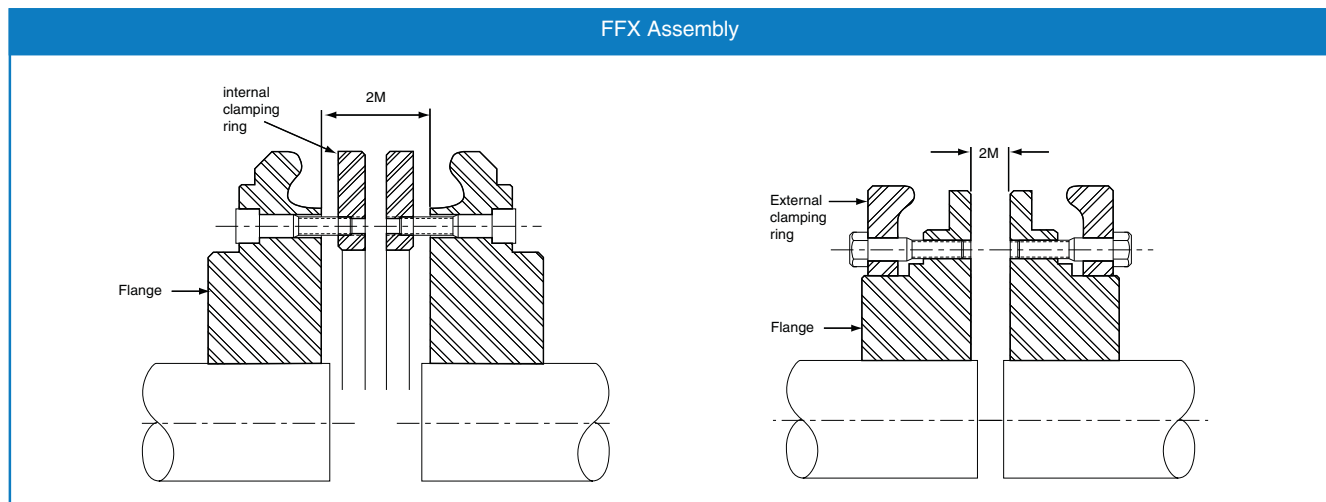

Table 3

FFX Coupling size	040	050	060	070	080	090	100	110	120	140	160	180	200	220	250
Parallel misalignment	1.0	1.3	1.6	1.9	2.1	2.4	2.6	2.9	3.2	3.7	4.2	4.8	5.3	5.8	6.6
Axial (end float) misalignment	1.3	1.7	2.0	2.3	2.6	3.0	3.3	3.7	4.0	4.6	5.3	6.0	6.6	7.3	8.2
Angular misalignment	4°	4°	4°	4°	4°	4°	4°	4°	4°	4°	4°	4°	4°	4°	4°
'2M' dimension	22	25	33	23	25	27	27	25	29	32	30	46	48	55	59
Clamping ring screw torque - Nm	15	15	15	24	24	40	40	40	50	55	80	105	120	165	165

Table 4

FFX Coupling Size	040 to 060	070 to 120	140 to 160	180 to 250
Gap between tyre ends	2	3	5	6